

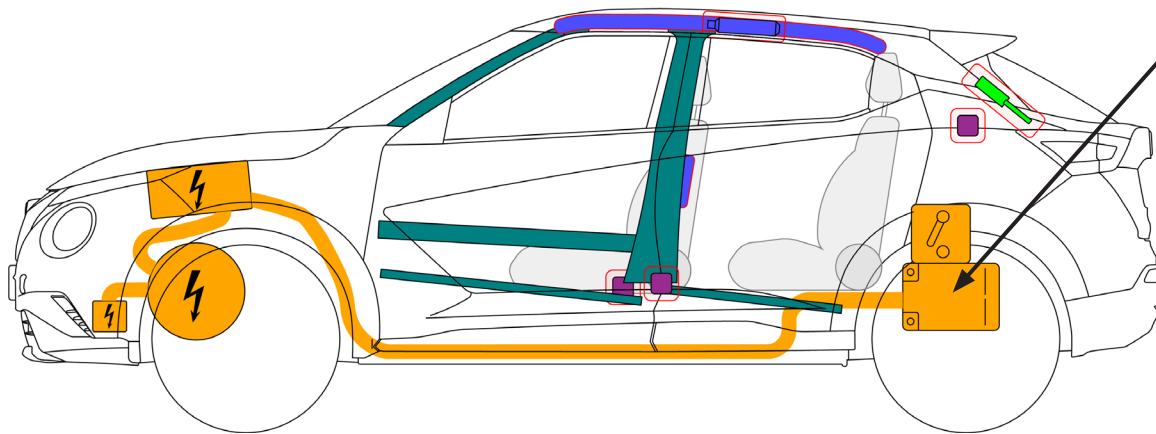

Nissan  
**Juke Hybrid**  
 TYPE: F16, 5-door SUV  
 (2022 - )

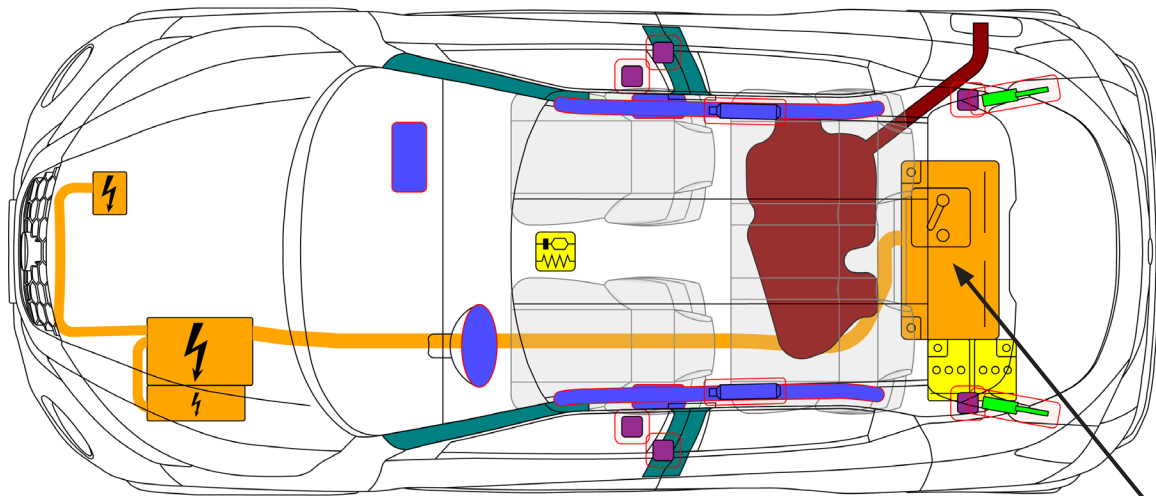
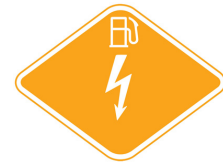

**286 V  
Li-ion**

Airbag	Gasgenerator	Forspænder til sikkerhedssele	SRS kontrolenhed	Batterispænding lavt
Gasfjeder / præinstalleret fjeder	Forstærket område	Højspændingsenhed, der afbryder højspænding	Højspændingskomponent	Batteripakke, højspænding
Højspændingskabel	Benzin / ethanol brændstoftank			

## 1. Identifikation / genkendelse



FRAVÆR AF MOTORSTØJ BETYDER IKKE, AT KØRETØJET ER SLUKKET. LYDLØS BEVÆGELSE ELLER ØJEBLIKkelig GENSTARTSKAPACITET ER MULIG, INDTIL KØRETØJET ER SLUKKET. BÆR PASSENDE PERSONLIGE VÆRNEMIDLER.

### Logoer



### Modelnavn



## 2. Immobilisering / Stabillisering / Løft

### Immobiliser køretøjet:

1. Blokér hjulene, brug bremsen og flyt gearvælgeren til (P) parkeringstilstand



### Løftepunkter:

 Passende løftepunkter

 Højspændingsbatteri

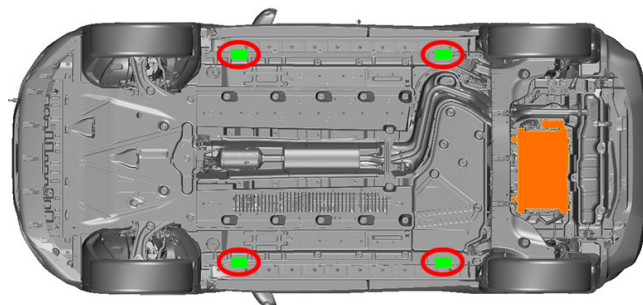

## 3. Deaktivering særlige farer / sikkerhedsforskrifter



I tilfælde af kollision med aktivering af sikkerhedsseleforstrammer og/eller udløsning af airbagsystem, deaktiveres højspændingssystemet automatisk. Selesystemerne er stadig aktive.

1. Hvis "Ready"-indikatoren på instrumentbrættet lyser, skal du trykke én gang på Start/Stop-knappen. Så vil højspændingssystemet være slukket

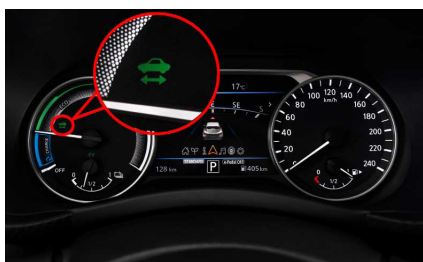

Fjern derefter den elektroniske nøgle, og hold en afstand til køretøjet på min. 5 m (16 fod)

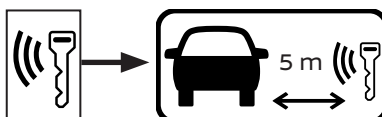

## Adgang til bagagerummet



## 2. Frakobl 12 volt batteri

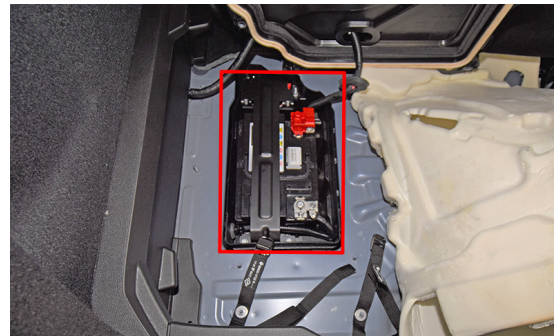
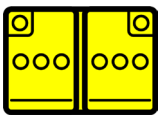

## 3. Deaktivering af højspændingssystem, anvend klasse 0 isolerende gummihandsker, når du bruger denne afbryderkontakt.

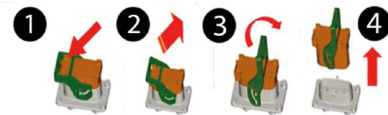
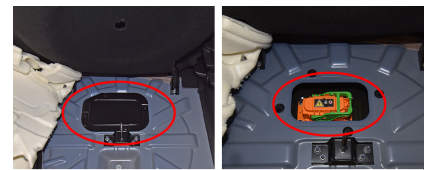
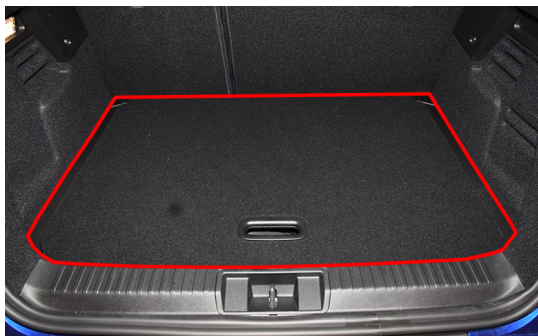

### Sikkerhedsinstruktioner:

Undlad at røre ved, skære i eller åbne nogen af de orange højspændingseffekt kabler eller højspændingskomponenter!

## 4. Adgangveje til tilskadekommande

### Højstyrkestål i karrosseri og dør

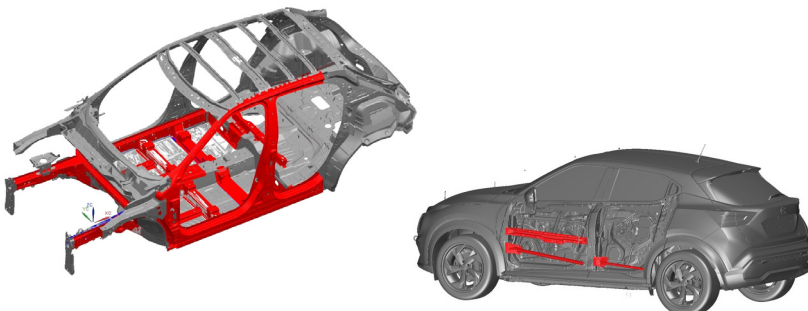

### Justering af ratstamme



# Nissan Juke HEV Type: F16, 5dr SUV (2022 - ) – Yderligere sider

## Sædejustering

















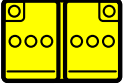

## Glastyper:

A. Lamineret glas

B. Hærdet glas



## 5. Oplagret energi / væsker / gasser / faste stoffer

	Lithium-ion 150-286V						
	12V						
	R-1234yf 500 25 g						
	46L						



Når traditionelt kølemiddel lækker (kontrollér reservoir) fra højspændingsbatteriets kølesystem, kan højspændingsbatteriet blive ustabil og skabe risiko for termisk afledning. En stigende temperatur i batterienheden kan være et tegn på termisk afledning.



## 6. I tilfælde af brand



**BRUG STORE MÆNGDER RENT VAND**



**POTENTIEL RISIKO FOR GENANTÆNDING AF HØJSPÆNDINGSBATTERI/FORSINKET BRAND!**

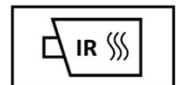

Redningsmandskab skal altid beskytte sig selv med personligt beskyttelsesudstyr (PPE), herunder et selvstændigt åndedrætsværn (SCBA) og tage passende forholdsregler for at beskytte civile, der befinder sig i vindretningen fra hændelsen.



**GASSTRENGE, RISIKO FOR MISSILEFFEKT**



## 7. I vand

- Der er ingen øget risiko for elektrisk stød i vand som følge af højspændingssystemet;
- Fjern om muligt køretøjet fra vandet, og fortsæt med deaktiveringsproceduren for dette køretøj. (se kapitel 3).
- Kontakt din forhandler/producent.

## 8. Bugsering / transport / opbevaring

### Placering bugseringsøje



### Placering af forreste krog



### Placering af bagkrog



### Bugsering

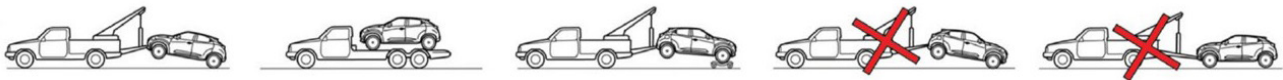

**OPBEVAR KØRETØJET UDENDØRS PÅ EN PARKERINGSPLADS I SIKKER AFSTAND ( $\geq 5$  M) FRA ANDRE GENSTANDE ELLER KØRETØJER OMKRING**

**POTENTIEL RISIKO FOR GENANTÆNDING AF HØJSPÆNDINGSBATTERI/FORSINKET BRAND!**

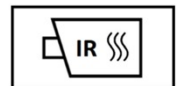

## 10. Piktogram information

	Fjern smartnøglen		Hybrid elektrisk køretøj på brændstof i klasse 2
	Advarsel om høj spænding		Brandfarlig
	Advarsel		Farlig for menneskers sundhed
	Advarsel; lav temperatur		Akut forgiftning
	Klimaanlæg		Eksplodiv
	Brug vand til at slukke ilden		Ætsende stoffer
	Brug termisk infrarødt kamera		Bagagerum